

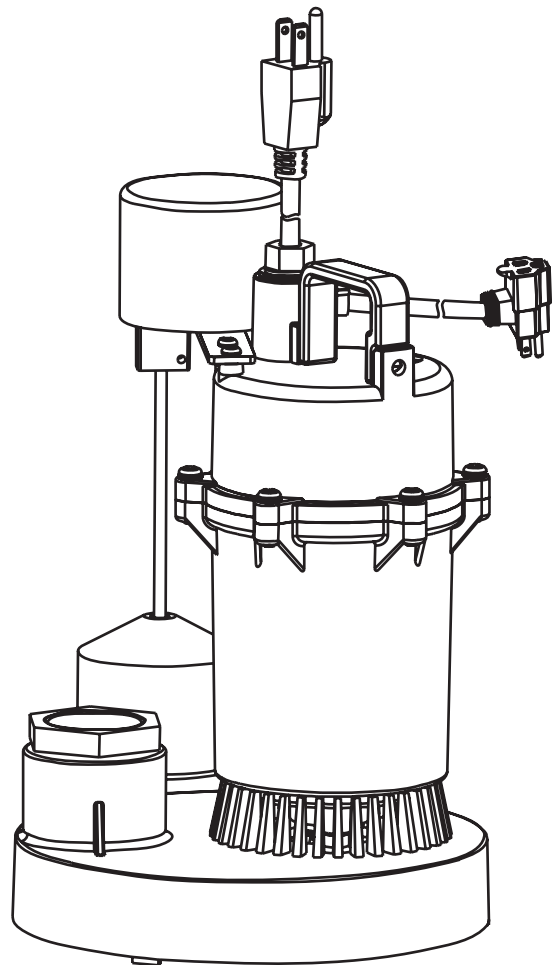

1/3 HP Submersible Sump Pump with Vertical Float Switch

Item 68476 Specifications

Float Switch Operation Height	7.1 IN. ON / 2.8 IN. OFF
Electrical Requirements	120V~ / 60Hz / 7.6A
Power Cord Length	10 FT.
Maximum Capacity	3000 GPH
Maximum Delivery Height	25 FT.
Discharge Size	1.5 IN. NPT (includes 1.25 IN. Adaptor)
Maximum Water Temperature	77° F (25°C)



⚠ WARNING

Read the separate Sump Pump Safety Warnings, Installation and Operation Instructions before using this product.

Failure to do so can result in serious injury. **SAVE THIS SPECIFICATION SHEET AND THE SUMP PUMP SAFETY WARNINGS, INSTALLATION AND OPERATION INSTRUCTIONS FOR FUTURE REFERENCE.**

When unpacking, make sure that the product is intact and undamaged. If any parts are missing or broken, please call 1-800-444-3353 as soon as possible.

Visit our website at: <http://www.harborfreight.com>

PLEASE READ THE FOLLOWING CAREFULLY

THE MANUFACTURER AND/OR DISTRIBUTOR HAS PROVIDED THE PARTS LIST AND ASSEMBLY DIAGRAM IN THIS MANUAL AS A REFERENCE TOOL ONLY. NEITHER THE MANUFACTURER OR DISTRIBUTOR MAKES ANY REPRESENTATION OR WARRANTY OF ANY KIND TO THE BUYER THAT HE OR SHE IS QUALIFIED TO MAKE ANY REPAIRS TO THE PRODUCT, OR THAT HE OR SHE IS QUALIFIED TO REPLACE ANY PARTS OF THE PRODUCT. IN FACT, THE MANUFACTURER AND/OR DISTRIBUTOR EXPRESSLY STATES THAT ALL REPAIRS AND PARTS REPLACEMENTS SHOULD BE UNDERTAKEN BY CERTIFIED AND LICENSED TECHNICIANS, AND NOT BY THE BUYER. THE BUYER ASSUMES ALL RISK AND LIABILITY ARISING OUT OF HIS OR HER REPAIRS TO THE ORIGINAL PRODUCT OR REPLACEMENT PARTS THERETO, OR ARISING OUT OF HIS OR HER INSTALLATION OF REPLACEMENT PARTS THERETO.

Parts List and Assembly Diagram

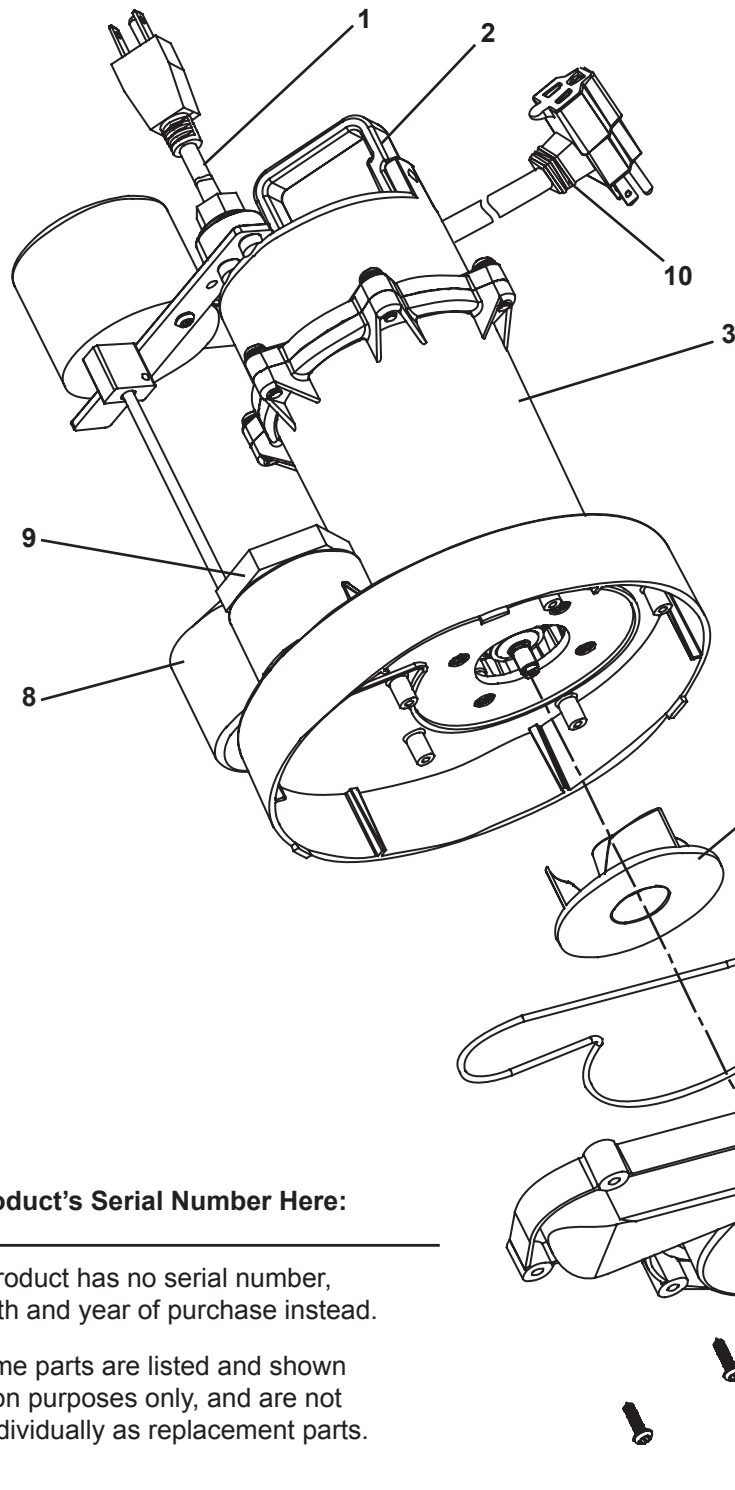

Part	Description	Qty.
1	Pump Cord	1
2	Handle	1
3	Motor	1
4	Impeller	1
5	Gasket	1
6	Volute	1
7	Screw	7
8	Float Switch	1
9	Inlet	1
10	Float Switch Cord	1

Record Product's Serial Number Here:

Note: If product has no serial number, record month and year of purchase instead.

Note: Some parts are listed and shown for illustration purposes only, and are not available individually as replacement parts.



Sump Pump

Safety Warnings, Installation and Operation Instructions

⚠ WARNING

Read this material before using this product. Failure to do so can result in serious injury. **SAVE THIS SUMP PUMP SAFETY WARNINGS, INSTALLATION AND OPERATION INSTRUCTIONS AND THE SPECIFICATION SHEET FOR FUTURE REFERENCE.**

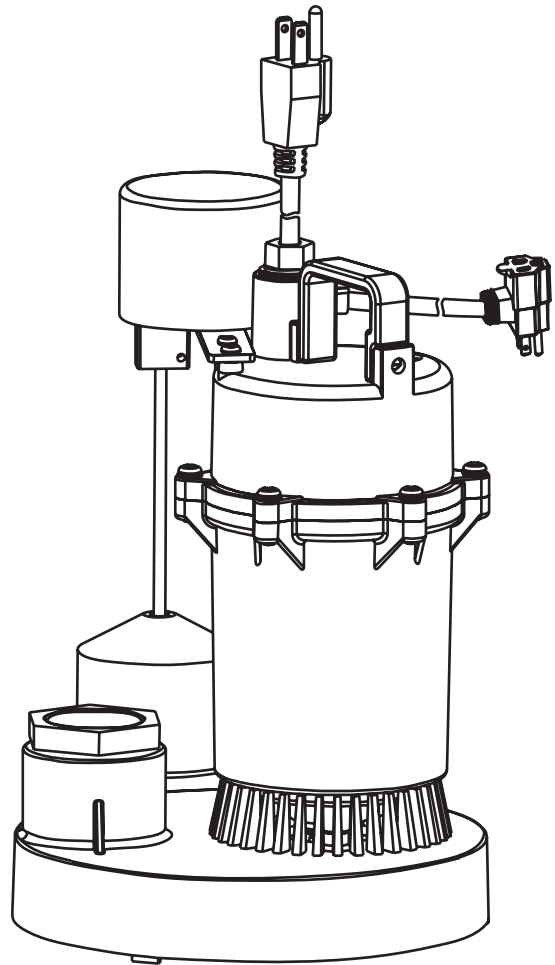

When unpacking, make sure that the product is intact and undamaged. If any parts are missing or broken, please call 1-800-444-3353 as soon as possible.

Note: There may be some slight differences in the *appearance* of the various sump pumps, however the instructions in this manual apply to all of such pumps provided by Harbor Freight Tools.

Visit our website at: <http://www.harborfreight.com>

Before start-up, note the following:

The pump can be connected to any shock-proof plug which has been installed according to regulations. The plug must have a supply voltage of 120 V~ at 60 Hz.

CAUTION

This pump has been evaluated for use with water only.

⚠ WARNING

IMPORTANT! For your own safety – before starting to run the pump, please have the following items checked by an expert:

1. Risk of electric shock – This pump is supplied with a grounding conductor and grounding-type attachment plug. To reduce the risk of electric shock, connect only to a properly grounded, grounding-type receptacle.
2. Risk of electric shock – This pump has not been investigated for use in swimming pool areas.
3. The electrical connections must be protected from moisture.
4. If there is danger of flooding, the electrical connections must be taken to higher ground.
5. Circulation of caustic fluids, as well as the circulation of abrasive materials, must be avoided at all costs.
6. The pump must be protected from frost.
7. The pump must be protected from running dry.
8. Access by children should also be prevented with appropriate measures.
9. Position the Pump on a flat, level, solid surface. Also secure the discharge pipe (not included) to a solid surface to ensure the stability of the Pump.
10. Do not use with an extension cord. If a GFCI-protected outlet is not close enough to the pump, contact a licensed electrician to install a new one. All wiring must be performed by a licensed electrician and comply with the National Electric Code. Do not remove the round grounding pin from the plug.
11. Turn off power to all circuits before walking on a wet floor. If you cannot turn power off first, contact an electrician to turn off the power.
12. Install a backup pump and/or high water alarm as an additional safeguard against flooding.
13. **WARNING:** Handling the Power Cord on this product will expose you to lead, a chemical known to the State of California to cause cancer, and birth defects or other

reproductive harm. Wash hands after handling. (California Health & Safety Code § 25249.5, *et seq.*)

14. The warnings, precautions, and instructions discussed in this instruction manual cannot cover all possible conditions and situations that may occur. It must be understood by the operator that common sense and caution are factors which cannot be built into this product, but must be supplied by the operator.

Fluid Type

The Pump is designed for use with water with a maximum temperature of 77° F (25°C). Do not use the pump for other fluids, especially not fuels, cleaning fluids, or other chemical products.

Specifications

See Specifications for your model on included sheet.

Installation

The submersible motor pump must be installed in a stationary position with either:

- a. A fixed pipeline or
- b. A flexible hose pipe.

Please note!

1. Do not install the pump by suspending it unsupported from its delivery pipe or power cords. The pump must be suspended from the handle or be placed on the bottom of the shaft. To ensure that the pump works properly, keep the bottom of the shaft free from sludge and dirt of all kinds.
2. If the water level sinks too low, any sludge in the shaft will dry out and stop the pump from starting. To help ensure the pump will start as required, check the pump regularly with start-up tests.

Power Supply

1. The pump is equipped with a shock-proof plug according to regulations. The pump is designed to be connected to 120 V~, 60 Hz, Ground Fault Circuit Interrupter (GFCI) protected safety socket.
2. Make sure that the socket is sufficiently secured and is in excellent condition.
3. When the plug is inserted into the socket the pump will be on standby.
4. Connect the Pump Power Cord only through the Float Switch Cord plug to prevent dry running.

▲WARNING! If either power cord or plug is damaged, do not use the pump. The power cord or plug may only be repaired by a certified electrician.

Areas of use

1. This pump is designed to pump clear water only.
2. This pump is designed for use as a basement pump. When installed in a shaft, this pump provides some protection from basement flooding.
3. This pump can also be used to transfer water (e.g. household, farming, plumbing).

Installation Instructions

1. Construct a basin that is at least 22 IN. deep and at least 14 IN. in diameter.

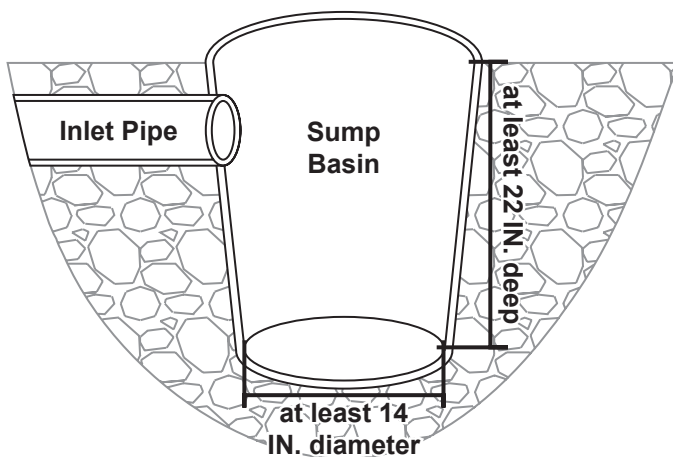

Figure A: Sump Basin

2. Position pump on solid surface so that the Float Switch is away from the inlet pipe and at least 1 IN. away from all obstructions throughout its movement.

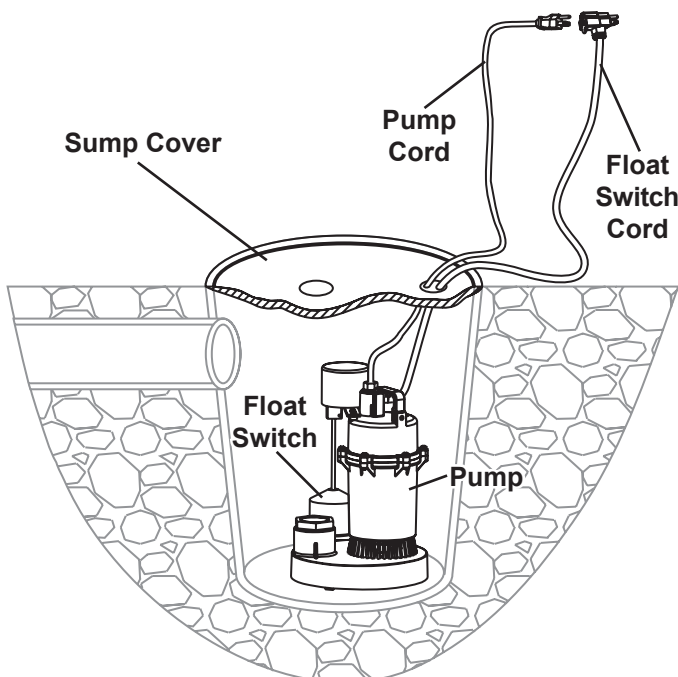

Figure B: Pump Position

3. Fit a sump cover with a hole for the output pipe and power cords. Thread the Power Cords through their holes, but do not plug them in yet. Set the sump cover aside for now.

Note: The sump cover can also be fitted with a vent pipe, if desired.

4. Attach a discharge pipe to the Pump Outlet.

Note: Wrap all threaded connections with PTFE thread seal tape.

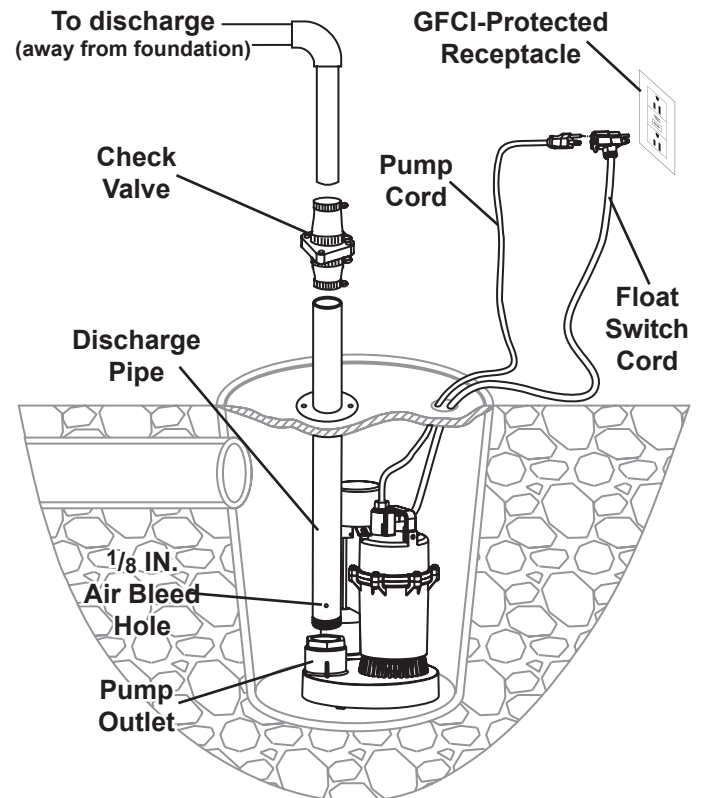

Figure C: Outlet Pipe and Plug

5. To prevent needless cycling, install a check valve onto the discharge pipe. This prevents water from flowing back after the pump shuts off.
6. **IMPORTANT:** Drill a 1/8 IN. diameter air bleed hole through the Discharge Pipe just above the lower Base to prevent Pump "airlock". A small spray of water out of this hole is normal while the Pump is running.
7. Install a gate valve or ball valve if required by building codes.
8. The ON/OFF height can be changed by adjusting the Float Switch.
9. Connect additional Discharge Pipe as needed to direct the water discharge at least 3 FT. away from the foundation. Slope the discharge pipe downward, away from the foundation. The discharge should be kept as short as possible with a minimum number of turns.

IMPORTANT: Do not exceed the Maximum Delivery Height of the Pump.

Operation

After reading these instructions, consider the following points before starting the pump:

1. Verify that the pump rests on the floor of the shaft, if it is not suspended by the handle.
2. Verify that the delivery pipe is properly connected.
3. Verify that the electrical connection is 120 V~, 60 Hz, and GFCI-protected.
4. Verify that the electrical socket is in good condition.
5. Verify that water and moisture cannot get near the power supply socket.
6. Verify that the pump is installed so as to prevent running dry.
7. Verify that the power cords do not have excess slack in the Sump Basin to prevent it from interfering with the Float Switch. Secure them to the Discharge Pipe if needed.
8. Dry the floor and your hands, then plug the Float Switch Cord into a grounded, GFCI-protected receptacle.
9. Plug the Pump Cord into the back of the Float Switch Cord's plug. The pump will then be on standby.

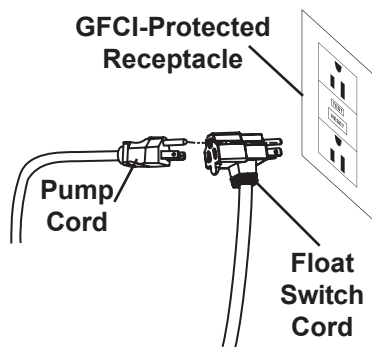

Figure D: Outlet Pipe and Plug

10. After connecting power to the pump and periodically afterwards, test the pump:
 - a. Fill the basin to above the Float Switch Operation ON Height. The pump should start pumping.
 - b. The pump should pump the water down to below its Float Switch Operation OFF Height and then stop pumping.
 - c. If the water drains back into the basin and restarts the pump, make sure the check valve is properly installed and working. Also make sure that all pipe connections are tight.

Note: It is the owner's responsibility to ensure the float switch is properly connected to the pump and can operate properly and freely without obstructions.

⚠️ WARNING

TO PREVENT SERIOUS INJURY FROM ACCIDENTAL OPERATION:

Unplug the Pump from its electrical outlet and ALLOW TO COOL FOR AT LEAST 2 HOURS before performing any inspection, maintenance, or cleaning procedures.

1. **Before each use**, inspect the general condition of the Pump. Check for cracked or broken parts, damaged electrical wiring, clogged Impeller Cover, Impeller, Discharge Pipes, leaks and loose connections, and any other condition that may affect safe operation. If abnormal noise or vibration occurs, have the problem corrected before further use.
Do not use damaged equipment.
2. Keep the Sump Basin clean. Clean out the sump basin regularly and keep the cover in place to keep it clean. Sand and other debris can interfere with pump operation, can block the air bleed hole, or can cause premature wear.
3. Clean out the air bleed hole periodically.

Quarterly Maintenance

The below maintenance must be performed at least once every 3 months under optimal conditions. For frequent use, or dirty areas, more frequent maintenance is required.

1. Remove the Sump Basin Cover.
2. Clean sludge and debris from the bottom of the shaft.
3. Rinse the housing off with clean water.
4. Clean fibers from inside the pump housing with a pressure washer (not included).
5. If the pump housing cannot be cleaned from the outside, it must be thoroughly cleaned.
Unplug the power cords before maintenance.
Dismantle the bottom part of the pump as follows:
 - a. Remove the Screws at the bottom of the Base.
 - b. Remove the Base to expose the Impeller Cover and Impeller.
 - c. Clean the impeller with clean water.
 - d. To prevent damage, do not rest the pump on the impeller or pry against the impeller.
 - e. Reassemble in reverse order.
6. Make sure the float switch can operate freely, without obstructions.
7. Replace the Sump Basin Cover.

Cold Weather Storage

In cold weather, when the Pump is not in use, protect the interior of the Pump from freezing by draining the water and pumping a permanent type automobile anti-freeze containing a rust inhibitor through the system. A 50% mixture with water is recommended. Be sure to flush the system with a neutralizing liquid prior to re-use of the Pump.

Parts List and Diagram

See Parts List and Assembly Diagram for your model on included sheet.

Troubleshooting

Problem	Possible Causes	Possible Solutions
Pump runs, but will not deliver any water.	<p>Disconnect power cords immediately to prevent damage from running dry.</p> <ol style="list-style-type: none"> Pump “airlock”. Impeller trapped in an air bubble. Shut off valve closed (if installed). Filter clogged. Impeller clogged. Discharge Pipe frozen or blocked. Optional check valve stuck or installed backwards. 	<p>Disconnect power cords immediately to prevent damage from running dry.</p> <ol style="list-style-type: none"> Drill a 3/16 IN. diameter air bleed hole through the Discharge Pipe just above the Lower Base. Open valve. Clean out dirt and debris from filter. Remove Volute. Clean out dirt and debris from Impeller. Then replace Volute. Thaw pipe and/or remove debris. Examine and correct check valve.
Pump won't start or run.	<ol style="list-style-type: none"> Check power connections and circuits/fuses. Water level too low. Filter clogged. Impeller clogged. Motor damaged or worn out. 	<ol style="list-style-type: none"> Consult with an electrician. Allow water level to rise above the Float Switch Operation ON Height or move Pump to a lower location. Clean out dirt and debris from filter. Remove Volute. Clean out dirt and debris from Impeller. Then replace Volute. Pump must be replaced.
Excessive noise or vibration.	<ol style="list-style-type: none"> Debris in impeller. Discharge pipe restricted. Worn bearings. 	<ol style="list-style-type: none"> Remove filter, if equipped. Clean impeller. Then replace filter. Clean pump and discharge pipe. Straighten flexible hose. Pump must be replaced.
Pump starts and stops too frequently.	<ol style="list-style-type: none"> Water temperature too high. Back flow of water from discharge pipe. Extension cord used. 	<ol style="list-style-type: none"> Do not exceed 77° F (25°C). Install or inspect optional check valve. Eliminate use of extension cord. Have licensed electrician install GFCI-protected outlet near pump if needed.
Pump does not shut off automatically.	<p>DISCONNECT POWER CORDS FIRST TO PREVENT SERIOUS INJURY.</p> <ol style="list-style-type: none"> Pump Cord not connected through Float Switch Cord plug. Float Switch stuck. Check valve not installed properly or functioning. Defective Float Switch. 	<p>DISCONNECT POWER CORDS FIRST TO PREVENT SERIOUS INJURY.</p> <ol style="list-style-type: none"> Plug Pump Cord into back of Float Switch Cord plug. Check for free movement of Float Switch. Clear debris away from beneath Float Switch. Make sure check valve is properly installed and in working order. Unplug Pump from its electrical outlet. Do not use until qualified technician checks Pump for proper operation.



Follow all safety precautions whenever diagnosing or servicing the tool. Disconnect power supply before service.

LIMITED 90 DAY WARRANTY

Harbor Freight Tools Co. makes every effort to assure that its products meet high quality and durability standards, and warrants to the original purchaser that this product is free from defects in materials and workmanship for the period of 90 days from the date of purchase. This warranty does not apply to damage due directly or indirectly, to misuse, abuse, negligence or accidents, repairs or alterations outside our facilities, criminal activity, improper installation, normal wear and tear, or to lack of maintenance. We shall in no event be liable for death, injuries to persons or property, or for incidental, contingent, special or consequential damages arising from the use of our product. Some states do not allow the exclusion or limitation of incidental or consequential damages, so the above limitation of exclusion may not apply to you. THIS WARRANTY IS EXPRESSLY IN LIEU OF ALL OTHER WARRANTIES, EXPRESS OR IMPLIED, INCLUDING THE WARRANTIES OF MERCHANTABILITY AND FITNESS.

To take advantage of this warranty, the product or part must be returned to us with transportation charges prepaid. Proof of purchase date and an explanation of the complaint must accompany the merchandise. If our inspection verifies the defect, we will either repair or replace the product at our election or we may elect to refund the purchase price if we cannot readily and quickly provide you with a replacement. We will return repaired products at our expense, but if we determine there is no defect, or that the defect resulted from causes not within the scope of our warranty, then you must bear the cost of returning the product.

This warranty gives you specific legal rights and you may also have other rights which vary from state to state.

**3491 Mission Oaks Blvd. • PO Box 6009
Camarillo, CA 93011 • (800) 444-3353**



3491 Mission Oaks Blvd. • PO Box 6009 • Camarillo, CA 91302 • (800) 444-3353

www.harborfreight.com